

## Engineering Guidelines LD20 Base Station

### Connector Block for Electrical Contact



### Summary

The LD20 base station has been designed as an easy-to-use tool for evaluating the LD20 liquid flow sensor. The connector block performs two main tasks: it mechanically holds the sensor in place via a clip-in mechanism and provides a simple electrical interface between the contact pads of the sensor and a PC or any other system for first bench-top tests.

It can be anchored to a test bench using the mounting holes. Basic ESD protection is implemented as well. The male M8 connector is compatible with Sensirion's SCC1-USB sensor cable.

It is designed for testing purposes only and will not be commercially available, except as part of the LD20 Evaluation Kit. Customers are expected to refine the mechanical and electrical interfaces to best suit their application's needs.

## 1 Introduction

Sensirion's LD20 base station is meant for evaluation and testing purposes only. Customers are expected to design their own mechanical and electrical interface to best meet their application's requirements. In addition to usage instructions of Sensirion's LD20 base station, engineering guidelines are provided in the following which can be used as a reference design for a customized sensor interface.

## 2 Sensirion's LD20 Base Station

The LD20 base station is compatible with all LD20 versions available (e.g. LD20-2600B and LD20-0600L). Please follow the steps below when using and handling the LD20 base station:

### Connecting:

- Make sure all parts are clean and free of debris.
- Check the proper alignment of the LD20 sensor: the orientation is correct if the contact pads of the flow sensor are located above the spring pins. Press the LD20 sensor down into the base station. An audible "click" confirms the successful connection of the LD20 sensor.

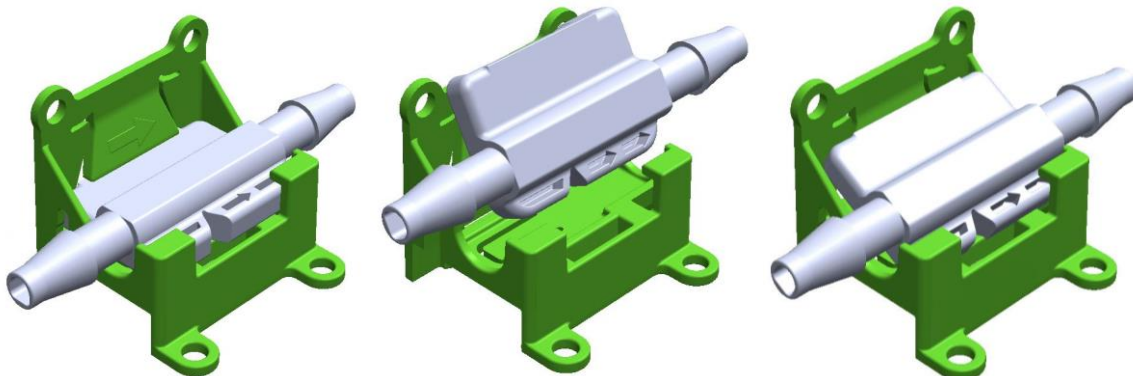

- Connect the base station's male 4-pin M8 connector with the SCC1-USB sensor cable for a plug-and-play connection to a PC. The sensors of the LD20 series don't support communication with the rest of Sensirion's SCC1 sensor cables (for analog of RS485 communication).

### Disconnecting:

- Stop any ongoing measurement first (e.g. by clicking "Stop" in the header of Sensirion's Viewer Software)
- To disconnect the sensor after testing, hold the base station in one hand without holding the sensor itself and push back the green clip (identifiable by the green arrow visible on the clip).

### Handling and cleaning:

- The LD20 base station is made from polyoxymethylene (POM). Check the chemical compliance with any media that you want to use for your measurements or for cleaning the base station.
- There is no fluidic sealing between sensor and base station nor between base station and the inserted PCB. Thus avoid liquids from spilling onto the base station and onto the sensor when clipped into the base station.
- Because of the contained electronics, the assembled LD20 base station cannot be gamma sterilized or autoclaved. Contact Sensirion in case of further questions about possibilities to clean or sterilize the base station.

### Disassembling:

- The short adapter cable (4-pin M8 to 4-pin Molex) can be manually disconnected from the PCB. Afterwards, also the PCB can be removed from the LD20 base station via a clip-in mechanism.
- Use a small screwdriver or a similar tool to press the clip holding the PCB in place slightly down while at the same time removing the PCB.

## 3 Electrical Engineering Guidelines for the Sensor Interface

The pad assignment of the LD20 sensor is shown in **Table 1**. The signals are fed to a male connector at the base station (type M8, 4-pin, threaded lock according to IEC 61076-2-104 / IEC 60947-5-2), which is in principle compatible with all of Sensirion's SCC1 sensor cables. See **Table 2** for the pinout of the M8 connector.

Pad	Description	Comments
1	SDA (data)	Serial data, bidirectional
2	VDD	Supply voltage
3	GND	Ground
4	SCL (clock)	Serial clock, bidirectional
5	VPP	Nonfunctional, connected to GND

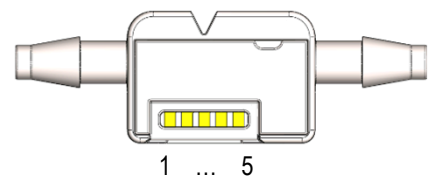

**Table 1:** Pad assignment of the LD20 sensor series

Pin	Description	Electrical pinout 4-pin M8 connector	Color Coding
1	SDA (data)	Serial data, bidirectional	Brown
2	GND	Ground	White
3	VDD	Supply voltage	Blue
4	SCL (clock)	Serial clock, bidirectional	Black

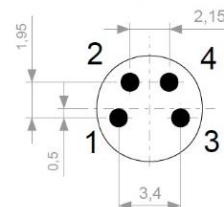

**Table 2:** Pinout at the connector side of the male M8 connector being part of the LD20 base station.

Digital communication between a master and the LD20 sensor (= slave) runs via the standard I<sup>2</sup>C-interface. The physical interface consists of two bus lines, a data line (SDA) and a clock line (SCL) which need to be connected via pull-up resistors to the bus voltage of the system.

For the detailed specifications of the I<sup>2</sup>C communication, please refer to the LD20 datasheet ([www.sensirion.com/ld20](http://www.sensirion.com/ld20)).

**Tip:** You may want to use the sensor's product ID for an easy identification and differentiation of the LD20 sensor type and its revision.

Please find below the schematic electronic circuitry as it is implemented in Sensirion's LD20 base station to enable stable I<sup>2</sup>C communication, to have some ESD protection, and to stabilize the supply voltage (see **Figure 1**). The resistors R3 and R4 are necessary pull-up resistors for the I<sup>2</sup>C interface. They are not part of the built-in PCB and consequentially need to be added by the customer (recommended resistance between 2.2 k $\Omega$  and 10 k $\Omega$  depending on setup and communication speed).

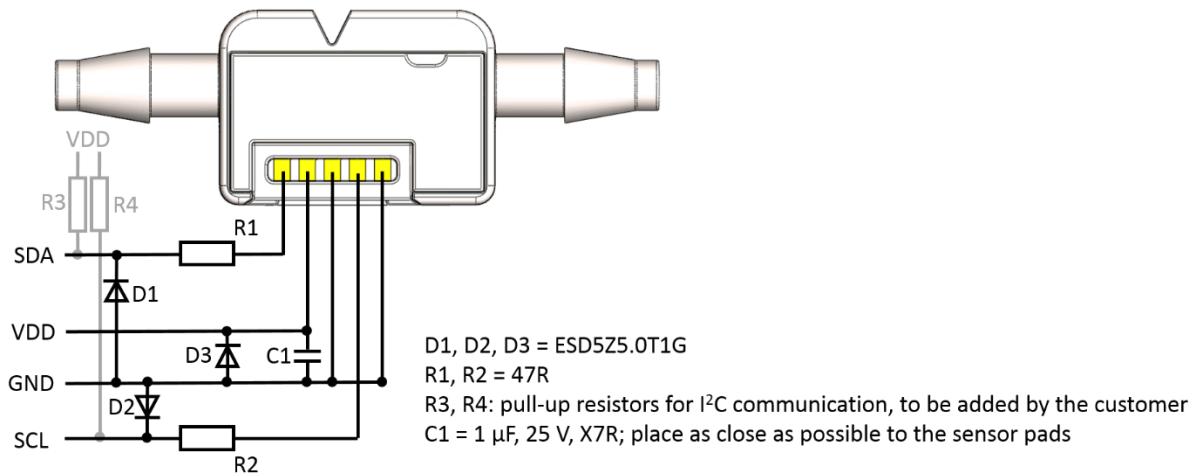

**Figure 1:** Electronic circuitry of the LD20 base station

As there is no level shifter or voltage regulator integrated on the PCB, the LD20 base station shall only be operated at the same voltage levels than the LD20 sensors (see the LD20 datasheet for details).

Ordering information for the spring-loaded connectors used in the base station design from Sensirion:

Manufacturer: Preci Dip  
 Manufacturer part number: 821-S1-005-30-014101  
 Digikey part number: 1212-1737-ND

Different spring pins can be used, i.e. with different connector heights, if customer's design allows.  
*Lead times might be several weeks.*

Ordering information for the Molex connector soldered to the PCB inside the base station from Sensirion:

Manufacturer: Molex, 1.25mm Pitch PicoBlade™ Connector System  
 Manufacturer part number: 53261-0471  
 Digikey part number: WM7622CT-ND

*Lead times might be several weeks.*

If required, wireless communication and power supply (e.g. batteries) can be added to the customized connector interface to enable portable or wearable designs.